

**CREATE YOUR OWN
MONSTER**
FRANKENSTEIN
Made with Pride **TRIKES** Pleasanton, KS, U.S.A.

Installation Guide

Sportster

34" Sport Trike Kit

2004 & UP



INCLUDED IN YOUR TRIKE KIT:

COMPONENTS

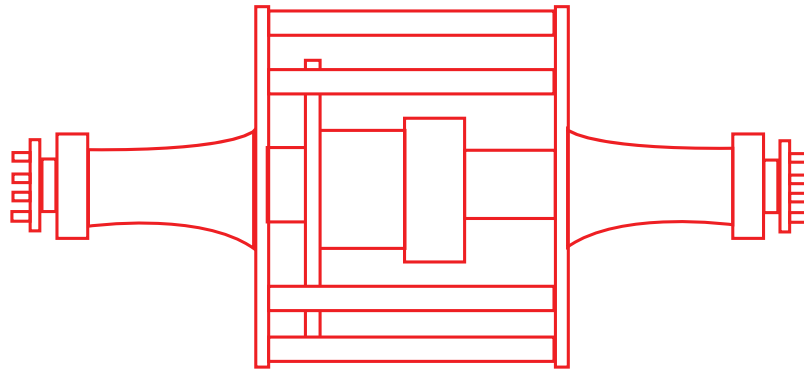

Frankenstein Trikes Rear End

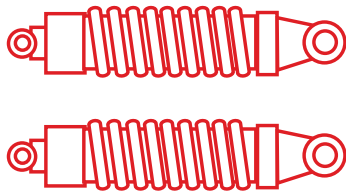

2 Sport Shocks

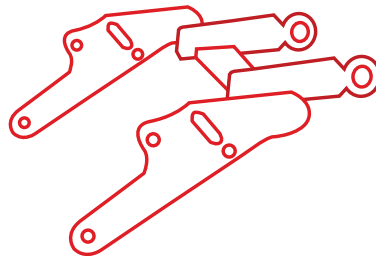

Swing Arm

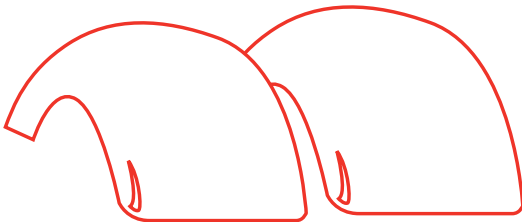

2 Sport Fenders

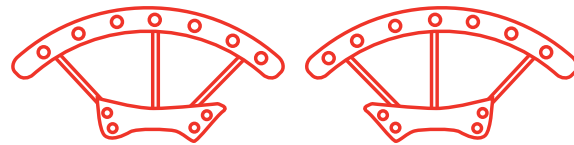

2 Fender Brackets

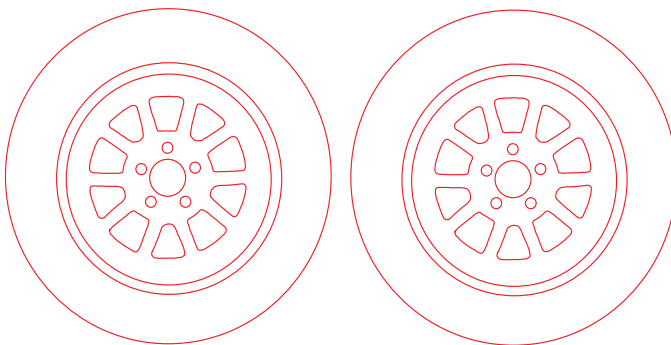

2 Race Star 15" X 8" wheels style FST-10-580146-SM



10 lug nuts

1

2 Center caps and 2 - 215/60R15 tires

HARDWARE

PULLEY MOUNTING

5 pcs. - 7/16" -14 x 1 1/2" Grd. 8 (Gold) Bolt

5 pcs. - 7/16" Lock Washer

Pulley mounting hardware can be found installed on rear end.

FENDER MOUNTING

14 pcs. - 3/8" - 16 x 1" Grd. 5 (Zinc) Bolt

14 pcs. - 3/8" I.D. 1" O.D. 1/16" Thick Grd 5 Washer

12 pcs. - 3/8" -16 Nylock Nut

2 pcs. - 3/8" -16 Thin Nylock Nut

***NOTE!** Additional hardware used to mount fender brackets to the rear end are pre-installed onto the rear end.*

SHOCK MOUNTING

2 - 1/2" - 13 x 2 1/4" Grd. 8 Bolt (Lower)

2 - 1/2" - 13 x 3 1/2" Grd. 8 Bolt (Upper)

4 - 1/2" I.D. 1" O.D. 1/8" Thick Grd 8 Washer

2 - 1/2" I.D. 1 1/4" O.D. 1" Long Spacer (Upper)

WHEEL MOUNTING

10 - Lug Nuts



LOCTITE is included with every kit and must be used where instructed in this manual.

STAGE 1. Motorcycle Preparation:



Always refer to your Harley-Davidson owners manual before performing any work on your bike.

1. Secure front wheel so motorcycle won't tip, set jack under the motorcycle and raise the jack to take the weight off of the rear wheel.
2. Remove upper and lower belt guards.
3. Loosen axle adjusters on both sides.



Factory exhaust will be too long for your Frankenstein Trike Kit.

Remove factory exhaust. If you have short exhaust you can leave them attached. (as shown below)

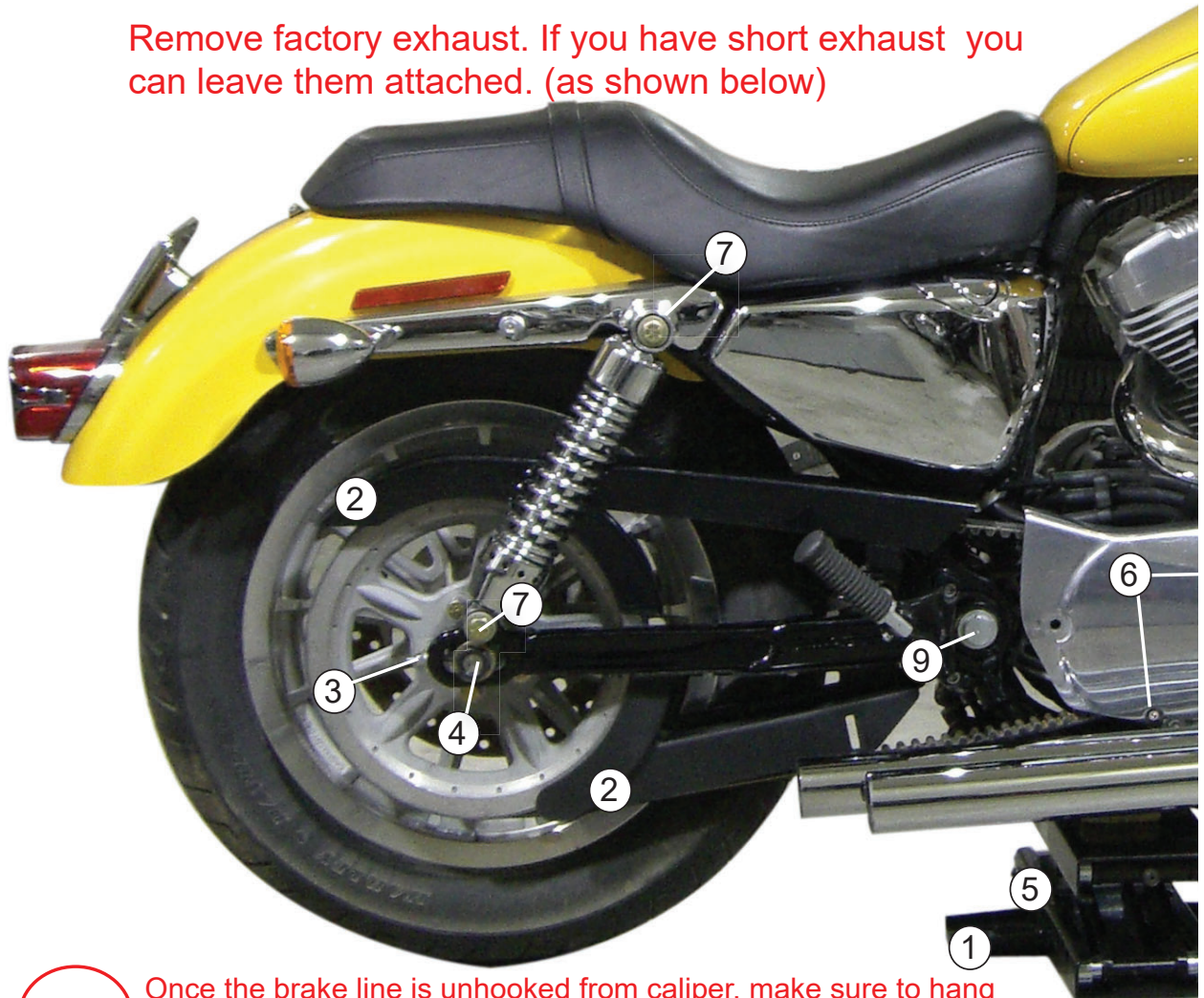

Once the brake line is unhooked from caliper, make sure to hang line upright so no fluid leaks out and no air gets trapped in the brake line.

4. Remove axle from wheel and swing arm. Slide the belt off of the pulley.
5. Raise the jack high enough to remove the rear wheel.
6. Remove front pulley cover.
7. Remove both shocks from the motorcycle.

Shown - 2004 Sportster your bike may vary depending on the year

8. Remove the allen bolt that holds the rear brake master cylinder reservoir, let the reservoir hang out of the way.



9. Remove swing arm pivot bolt or both sides. Remove swing arm.



TIP Now would be a good time to check the condition of your pulley and belt.

STAGE 2. Rear End Preparation/Installation:

1. With swing arm and rear wheel removed, have a friend help set a wheel and tire on the brake side of the rear end. Install with lug nuts.

TIP Install center cap into wheel before mounting.



Do not remove green tape, it will be used as a reference point in the following instructions.

2. Set the rear end on the wheel that was previously installed. Remove the five bolts to the spokes, Remove axle, axle housing and star plate as a unit.



3. Install Pulley. Install 7/16" pulley bolts with lock washers provided apply **red loctite** and torque the pulley bolts. Have friend help hold the center section of the rear end with a screw driver through a hole in the rotor through one of the holes in the star plate. Torque the pulley bolts to 65 ft. lbs. Install belt over pulley as shown, the belt should be inside of all spokes except the one that is marked with the green tape.



4. Remove spoke that is marked with the green tape. Install spacer on spigot of the differential housing.



5. Install axle, axle housing and star plate as a unit, Line up points of the star plate with the green tape. Install bolts through star plate to the spokes.

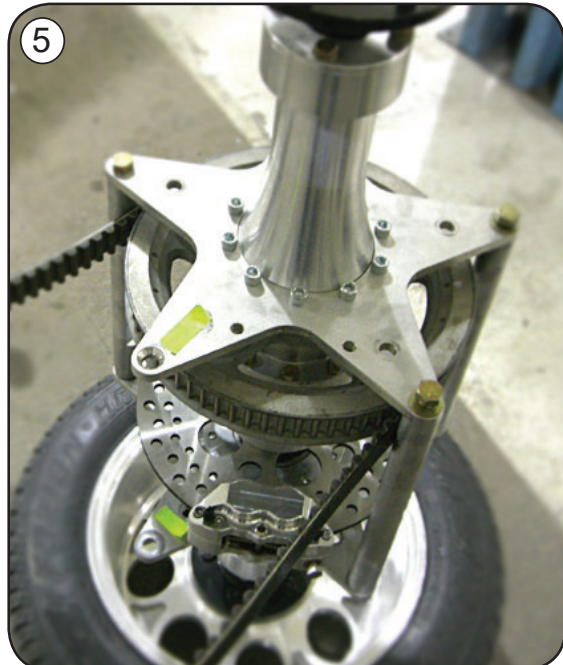

6. Install swing arm on rear end. Refer to diagram for placement of washers and spacers.

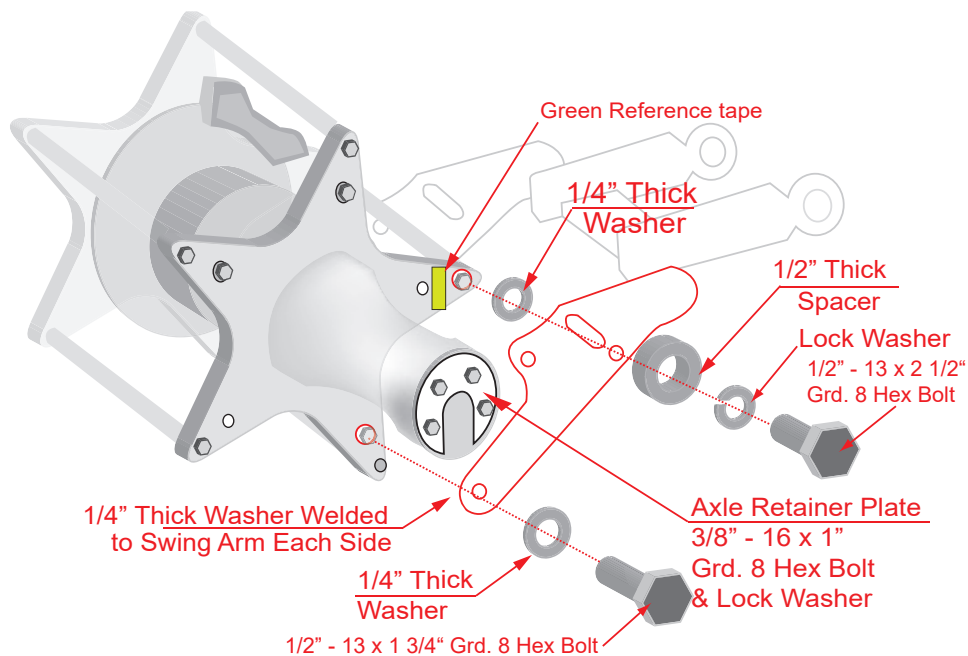
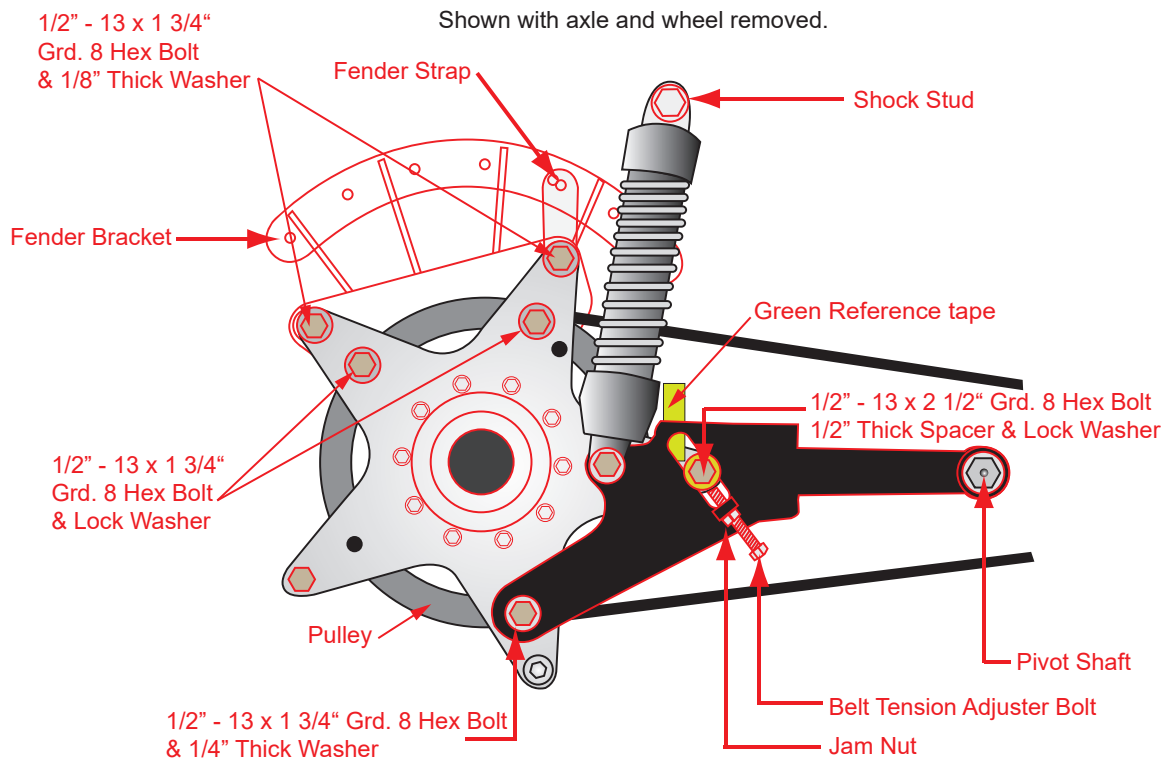

7. Have a friend help hold the swing arm. Install spoke previously removed as shown. Do not tighten the bolts that mount the swing arm to the rear end.

TIP Install center cap into wheel before mounting.

8. Install other wheel and tire on the axle. Install with lug nuts.



9. Roll the rear end and position it behind the bike.



Please Note:
10. 2 black Delrin Bushings are included with the kit. Install these into the rubber isolator before installing the swing arm.

11. Install swing arm pivot shaft and pivot bolts apply loctite.



LOCTITE

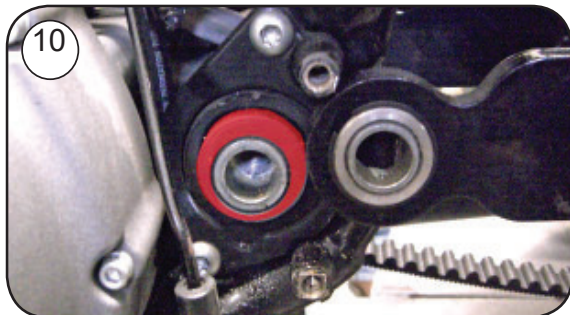
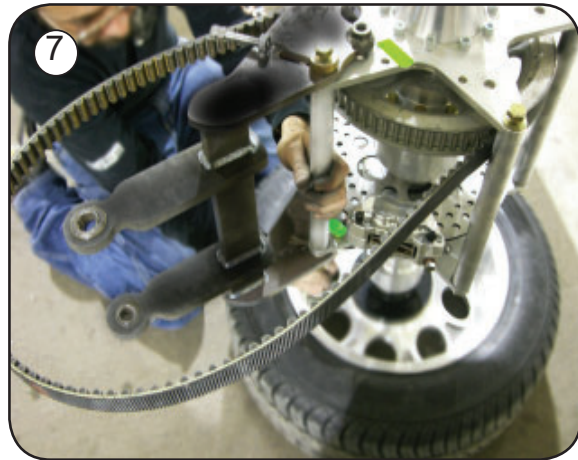

12. Slide belt over front pulley.
Torque pivot bolts
(60-70 ft. lbs.)



13. Attach fender brackets to fenders using supplied FENDER MOUNTING HARDWARE ★ *Note: side with more space from bolt holes to edge of fender goes toward the front.*

Configuration A. (standard) for 15x8 wheels & tires and 11" fenders

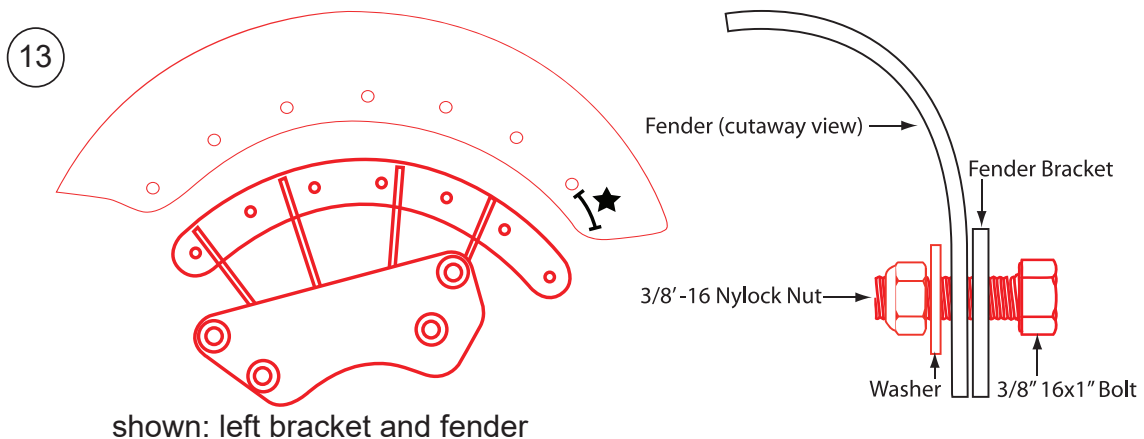

14. Remove top two star plate to spoke bolts and two bolts and lock nuts just below bolts previously removed, on one side at a time. Install fender and bracket on the rear end. Apply blue loctite. Install top two star plate bolts. Install lower mounting bolts and lock nuts on fender bracket. Install fender and fender bracket on other side as previously described. Torque upper fender bracket bolts to 60 ft. lbs hold spoke with adjustable wrench on flat area of spoke. Torque lower fender bracket bolts to 60 ft. lbs.



15. We have included a strap to reduce vibration. Install strap in the third bolt position from the front. Use Loctite on bolt to secure gold thin nylock nut. Thick side of strap attaches to the star plate on the rear end, narrow end of strap attaches to fender. *(please note this is only used on kits with 15x8 wheels and 215/60/15 tires)*

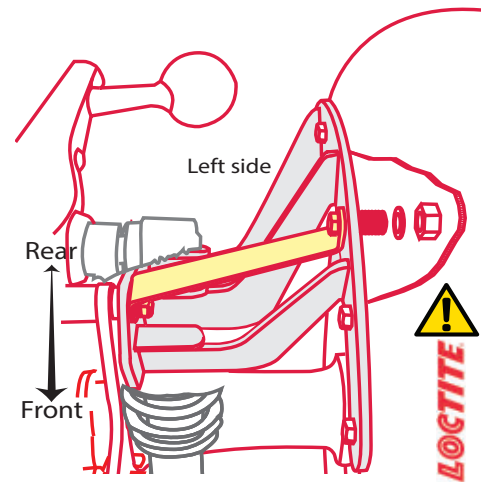



16. Remove remaining star plate bolts one at a time apply blue loctite and hold adjustable wrench on flat area of spoke to torque bolts to 60 ft. Lbs.

 Do not torque front spoke at this time.

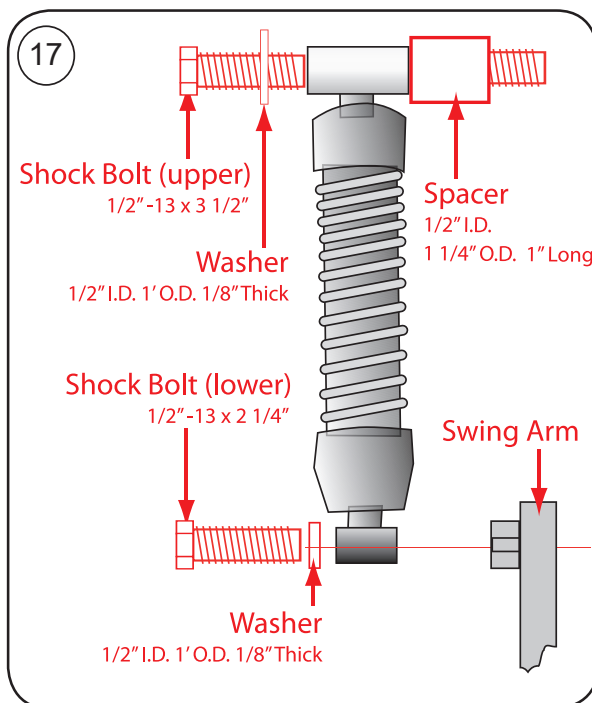

17. Install shocks with the provided shock mounting hardware. Torque shock bolts (upper 45-50 ft.lbs. / lower 55 ft.lbs.)



18. Adjust belt tension to factory specs.
 *The trike must be sitting on the ground on its suspension to adjust the belt.*



19. Tighten jam nut on adjuster bolts.

20. Torque the four rear end mounting bolts to 60 ft. lbs. hold adjustable wrench on flat area of spoke. Use blue loctite.

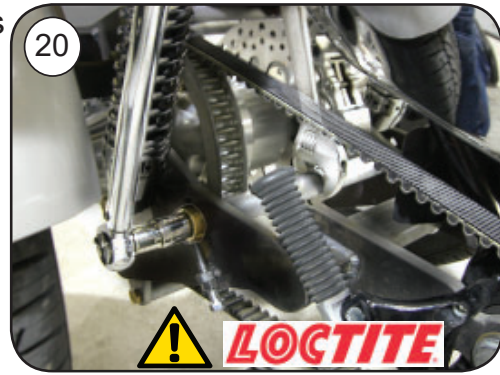

21. Install front pulley cover. Install the allen bolt that holds the rear brake master cylinder reservoir, hook up stock brake line, bleed rear brake.
22. Tighten lug nuts on rear wheels torque 78 to 85 ft. lbs. and go for a ride. Re-torque lug nuts after 25 miles or 100 mile maximum.

Tip: Recommended tire pressure is 25psi.



Note: Initially the brake and rotor need to be worn in before maximum braking can be achieved. Please use caution.

Our Trike rear ends are made from all 6061 T6 billet aluminum, except for our Light Sport Std. Trike rear end, which has 3/8" thick steel star plates, powder coated silver, instead of 1" thick billet aluminum star plates that we use on all our other Trike rear ends.

All of our rear ends have a Dana 30 differential, packed with Moly EP grease. 9" Ford street/strip axles with a bolt pattern of 5 studs on 4 1/2" bolt circle, wheel studs are 1/2" -20. HHI/Frankenstein 4 piston billet caliper, 11 1/2" stainless steel brake rotor, or optional outboard Brakes with two HHI/Frankenstein 4 piston billet calipers and two 11" stainless steel brake rotors. We only use top quality new parts in our manufacturing of "Frankenstein Trikes" rear ends.

Replacement Parts

Differential seal: National oil seal # 481213 \$3.50 each

Differential Bearing: # 62102RS \$15.00 each

Axle Bearing: BCA # RW207-CCRA \$55.00 each

Brake Pads: HHI-101-001 \$30.00 pair

prices subject to change

